

# JS100-C1

## Compact Speaker



### FEATURES

- Improved speaker driver unit tested for extreme temperature test and weather tests for long-lasting durability.
- High sound pressure output exceed SAE requirement.
- Compact and durable design with Fibre Reinforced Nylon housing & Cast Aluminium driver unit.
- Industrial standard L-Bracket and U-Bracket for versatile installation.

### SPECIFICATIONS

**Compliant:** SAE J1849 (EVS3), CA Title 13  
(when used with compatible 100W Siren Amplifier)

**Driver:** Neodymium Magnet

**Rated Wattage:** 100W

**Impedance (AC):** 11  $\Omega$

**DC Resistance:** 7.2  $\Omega$

**Weight:** 2.05 Kg

**Housing:** Fibre Reinforced Nylon and Cast Aluminium

**Storage Temperature:** -40°C~75°C

**IP Rating:** IP54K

**Sound Output:** 121.83 dBA @ 3M (9.84')

**Wires:** White (SPK+) - 35cm (20AWG)  
Black (SPK-) - 35cm (20AWG)

### SOUND PRESSURE LEVEL

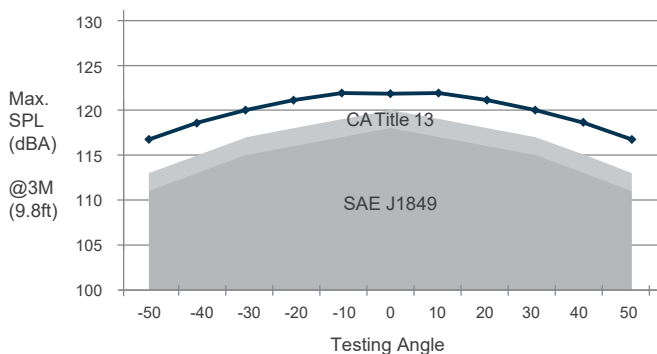

### DIMENSIONS

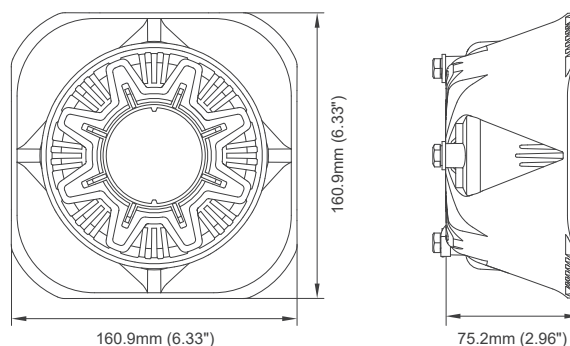

### PART NO.

- 17030045 (Speaker w/o Bracket)
- 17030052 (Speaker w/ L-Bracket)
- 17030069 (Speaker w/ U-Bracket)

### ACCESSORIES

- 17030076  
L-Bracket



- 17030083  
U-Bracket

